

Ex Fans — Fans for use in explosion-capable areas Axial fans, Roof fans, Duct fans

Installation and Operating Instructions

GB

Document in original language | · 002



© Copyright Systemair AB
All rights reserved
E&OE

Systemair AB reserves the rights to alter their products without notice.
This also applies to products already ordered, as long as it does not affect the previously agreed specifications.

Contents

1	General information	1	8.4.1	Lightning protection device	20
1.1	Notice symbols	1	9	Electrical connection	20
1.1.1	Instruction symbols	1	9.1	Protecting the motor	21
2	Information on the explosion-protection devices	1	9.2	Variable-speed fans	21
3	Important safety information	2	10	Commissioning	22
3.1	Personnel	3	10.1	Safety information	22
3.2	Personal protective equipment	3	10.2	Preconditions	22
3.3	5 rules of electrical safety	3	10.3	Tests	22
4	Warranty	3	11	Operation	23
5	Delivery, transport, storage	4	11.1	Safety information	23
6	Description	5	12	Troubleshooting/maintenance/repair	23
6.1	Intended use	5	12.1	Troubleshooting	24
6.2	Description AXC-EX, AXCBF-EX	5	12.2	Maintenance	25
6.2.1	Accessories	6	13	Cleaning	25
6.2.2	Name plate and type key	7	13.1	Safety information	25
6.3	Description AW-EX	8	13.2	Procedure	26
6.3.1	Accessories	8	14	Deinstallation/dismantling	26
6.3.2	Name plate and type key	8	15	Disposal	26
6.4	Description RVK-EX	9	16	Commissioning Report	27
6.4.1	Accessories	9			
6.4.2	Name plate and type key	10			
6.5	Description DV-EX	11			
6.5.1	Accessories	11			
6.5.2	Name plate and type key	12			
6.6	Description MUB-EX	13			
6.6.1	Accessories	13			
6.6.2	Name plate and type key	14			
6.7	Technical data	14			
7	Marking	15			
8	Installation	16			
8.1	Installation AW-EX, AXC-EX, AXCBF-EX	17			
8.2	Installation RVK-EX	18			
8.3	Installation DV-EX	19			
8.4	Installation MUB-EX	19			

1 General information

1.1 Notice symbols



Danger

Direct hazard
Failure to comply with this warning will lead directly to death or to serious injury.



Caution

Hazard with a low risk
Failure to comply with this warning may lead to moderate injuries.



Warning

Potential hazard
Failure to comply with this warning may lead to death or serious injury.

Important

Hazard with risk of damage to objects
Failure to comply with this warning will lead to damage to objects.



Note:

Useful information and instructions

1.1.1 Instruction symbols

Instruction

- ◆ Carry out this action
- ◆ (if applicable, further actions)

Instruction with fixed sequence

1. Carry out this action
2. Carry out this action
3. (if applicable, further actions)

2 Information on the explosion-protection devices



Danger

Explosion protection!
This warning marks information which applies if the device is used in a potentially explosive atmosphere. Failure to comply with this information will result in loss of explosion protection and may lead to serious injury or death.



Warning

Hazard resulting from improper use of the fans.
These operating instructions and the fan name plate describe how to use the EX fans safely.

- ◆ Read the operating instructions completely and carefully.
- ◆ If used in potentially explosive atmospheres, examine the name plate. Only use type PRF-EX fans.



Warning

Protective clothing must be worn in potentially explosive atmospheres to reduce the risks to employee health.

- ◆ Wear protective equipment during all work in the vicinity of the fan, details see 3.2 *Personal protective equipment*, page 3.
- ◆ Comply with the information on personal protective equipment displayed in the work area.

**Warning**

Regarding the choice of material, the EX fans fulfil the requirements of Standard DIN 14986 (Construction of fans for use in potentially explosive atmospheres) as a result of specific protection measures in areas of potential contact between rotating and stationary components (rotor/intake nozzle). A safety clearance to the intake nozzle is guaranteed for the rotating part. The plant builder is responsible for selecting the materials for the fixed peripheral parts for fan designs without protective grids. Only pairs of materials according to Standard DIN EN 14986 are to be used.

**Warning**

The temperature class stated on the EX name plate (motor) must match the temperature class of the combustible gas which may occur, or the motor must have a higher temperature class.

**Danger****Explosion protection**

Transport damage or failure to comply with this information can lead to loss of explosion protection.

- ◆ In the event of recognisable transport damage, contact the manufacturer and do not put the device into operation.

**Warning**

The effects of lightning strikes must be limited so that hazards are prevented. In addition to protection against the effects of "direct" lightning strikes, this also includes protection against lightning strikes at a distance from the building. The latter can lead to hazards resulting from excess voltage.

- ◆ Carry out a risk analysis according to DIN VDE 0100, part 443, with a balance between protection and consequences, taking the probability of the occurrence of excess voltage into account.
- ◆ Protect all devices, protective systems and components by using suitable lightning and excess voltage protection measures.

**Warning****Ignition protection class „d“**

If fans are controlled using motors with a "d" ignition protection class with a frequency converter, then thermal protection via a PTC resistor in the motor is required.

3 Important safety information

Planners, plant builders and operators are responsible for the proper assembly and intended use.

- ◆ Read the operating instructions completely and carefully.
- ◆ Keep the operating instructions and other valid documents, such as the circuit diagram or motor instructions, with the fan. They must always be available at the place of use.
- ◆ Observe and respect local conditions, regulations and laws.
- ◆ Abide by the system-related conditions and requirements of the system manufacturer or plant constructor.
- ◆ Safety elements may not be dismantled, circumvented or deactivated.
- ◆ Only use the fan in a flawless condition.
- ◆ Provide generally prescribed electrical and mechanical protective devices.
- ◆ During installation, electrical connection, commissioning, troubleshooting, and maintenance, secure the location and premises against unauthorised access.
- ◆ Do not circumvent any safety components or put them out of action.
- ◆ Before any work on the fan, test absence of voltage.
Even when the motor is stopped, dangerous voltages may be present on terminals.
- ◆ Keep all the warning signs on the fan complete and in a legible condition.
- ◆ The device is not to be used by persons (including children) with reduced physical, sensory or mental capabilities, or lack of experience and knowledge, unless they have been given supervision or instruction.
- ◆ Do not allow children to play with the device.

3.1 Personnel

The fan may only be used by qualified, instructed and trained personnel. The persons must know the relevant safety directives in order to recognise and to avoid risks. The individual activities and qualifications can be found in Table 1 *Qualifications*, page 3.

Table 1 Qualifications

Activities	Qualifications	
Storage, operation, transport, cleaning, disposal	Trained personnel (see following note)	
Electrical connection, commissioning, electrical disconnection	Electrical expert or matching qualification	
Installation, disassembly	Fitter or matching qualification	
Maintenance	Electrical expert or matching qualification	Fitter or matching qualification
Repair	Electrical expert or matching qualification	Fitter or matching qualification
	Smoke extraction fans and EX fans only by agreement with Systemair.	



Note:

The operator is responsible for ensuring that personnel are instructed and have understood the contents of the operating instructions. If something is unclear, please contact Systemair or its representative.

3.2 Personal protective equipment

◆ Wear protective equipment during all work in the vicinity of the fan.

- protective working clothes
- protective working gloves
- goggles
- protective working shoes
- helmet
- hearing protection

3.3 5 rules of electrical safety

1. Disconnect (disconnection of the electrical system from live components at all terminals)
2. Prevent reactivation
3. Test absence of voltage
4. Ground and short-circuit
5. Cover or restrict adjacent live parts

4 Warranty

For the assertion of warranty claims, the products must be correctly connected and operated, and used in accordance with the data sheets. Further prerequisites are a completed maintenance plan with no gaps and a commissioning report. Systemair will require these in the case of a warranty claim. The commissioning report is a component of this document. The maintenance plan must be created by the operator, see section 12.2 *Maintenance*, page 25.

5 Delivery, transport, storage

Safety information

Warning: Risk from rotating fan blades

- ◆ Prevent access by unauthorised persons by safety personnel or access protection.

Warning: Suspended loads

- ◆ Do not walk under suspended loads.
- ◆ Make sure that there is nobody under a suspended load.

Delivery

Each fan leaves our plant in an electrically and mechanically proper condition. We recommend transporting the fan to the installation site in the original packaging.

Checking delivery

- ◆ Check the packaging and the fan for transport damage. Any findings should be noted on the cargo manifest.
- ◆ Check completeness of the delivery.

Unpacking

When opening the transport packaging, there is a risk of damage from sharp edges, nails, staples, splinters etc.

- ◆ Unpack the fan carefully.
- ◆ Check the fan for obvious transport damage.
- ◆ Only remove the packaging shortly before assembly.

Transport

Safety information

Warning: Electrical or mechanical hazards due to fire, moisture, short circuit or malfunction.

- ◆ Never transport the fan by the connecting wire, terminal box, impeller, protection grille, inlet cone or silencer.
- ◆ In open transport, please make sure that no water can penetrate into the motor or other sensitive parts.
- ◆ We recommend transporting the fan to the installation site in the original packaging.

Caution: If transported without care during loading and unloading, the fan may be damaged.

- ◆ Load and unload the fan carefully.
- ◆ Use hoisting equipment that is suitable for the weight to be hoisted.
- ◆ Observe the transportation arrows on the packaging.
- ◆ Use the fan packaging exclusively as transport protection and not as a lifting aid.

Storage

- ◆ Store the fan in the original packaging in a dry, dust-free location protected against weather.
- ◆ Avoid the effects of extreme heat or cold.

Hazard due to loss of function of the motor bearing

- ◆ Avoid storing for too long (recommendation: max. 1 year).
- ◆ Check that the motor bearing functions properly before installation.

6 Description

6.1 Intended use

Intended use AW-EX, AXC-EX, AXCBF-EX, DV-EX, RVK-EX, MUB-EX

- The fans are intended for installation in ventilation systems.
- The fans are exclusively intended for conveying air in explosion-capable atmospheres according to the data on the name plate and this manual.
- The temperature of the air transported through the fan must not exceed the temperature range stated on the name plate.
- The temperature on the name plate (motor) must match the temperature class of the combustible gas which will possibly occur.

Incorrect use

Incorrect use refers mainly to using the fan in another way to that described. The following examples are incorrect and hazardous:

- Conveying of aggressive media
- The fan is not suitable for intake air with a dust content so high that dust deposits on the impeller or the fan housing.
- Operation of the fans with motors of „e“ ignition protection class with frequency converter.
- Conveying of abrasive, combustible air or air with solid particles.
- Operation without duct system or protection grille
- Operation with the air connections closed

6.2 Description AXC-EX, AXCBF-EX

Material of the housing:	Galvanized steel
Material of the impeller:	Aluminium die cast
Speed control:	By frequency converter (See accessories in our online catalogue)
Motor protection:	By integrated PTC resistor (A motor protection device with EC test type certification has to be used. See accessories in our online catalogue)
Temperature classes:	T1, T2, T3, T4
Classification:	Zone 1, Zone 2
Category:	2G
Ignition protection class:	Ex d, Ex e, Ex h
Group:	IIA, IIB, IIC

- Others:
- AXCBF-EX: Motor outside the air flow.
 - AXC-EX: Supplied with Ex e connection box on the outside of the housing.

Temperature [°C]	Max. input power in proportion to nominal power in [%]
40	100
45	95
50	90
55	85
60	80

6.2.1 Accessories

Horizontal installation

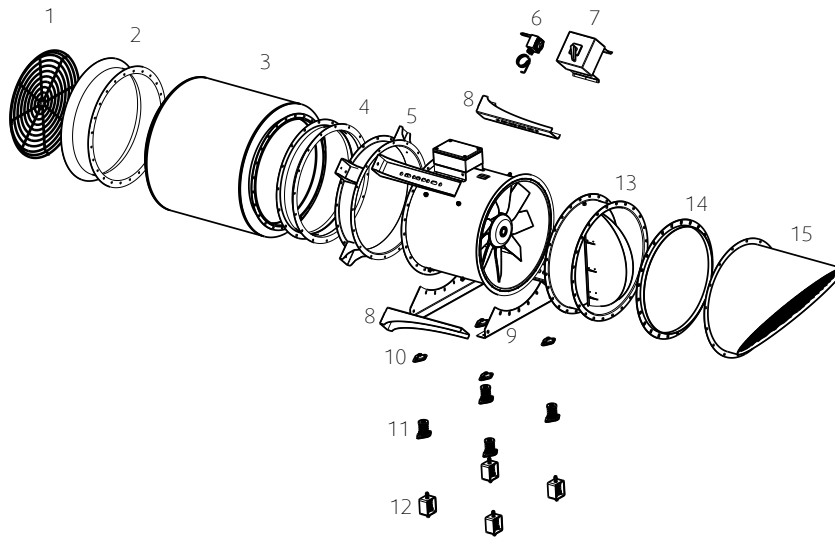

Vertical Installation

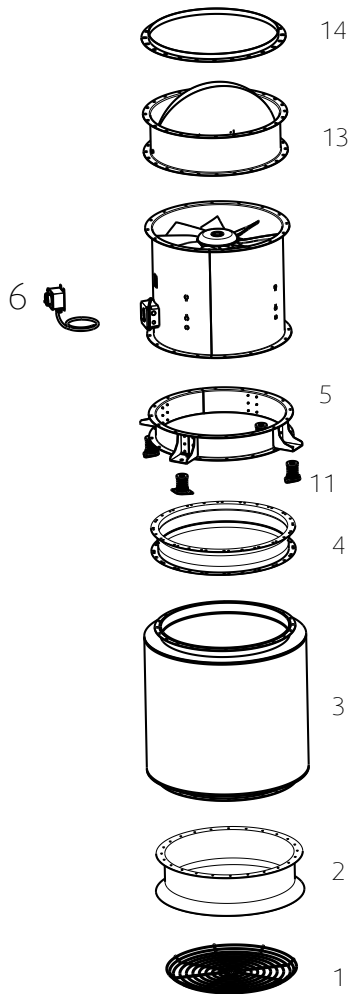

1	SG	Protection guard
2	ESD-F	Inlet cone
3	RSA	Silencer
4	EV-EX	Flexible connection
5	MPR	Mounting ring from size 315 to 1000
6	REV-ATEX	Isolator switch
7	REV-ATEX	Isolator switch
8	MP	Mounting bracket from size 1120
9	MFA	Mounting foot
10	SD	Rubber anti-vibration mounts
11	FSD	Spring anti-vibration mounts
12	ZSD	Suspension spring anti-vibration mounts
13	LRK-EX	Air operated damper
14	GFL	Counter flange
15	ABS	Outlet cowl

6.2.2 Name plate and type key

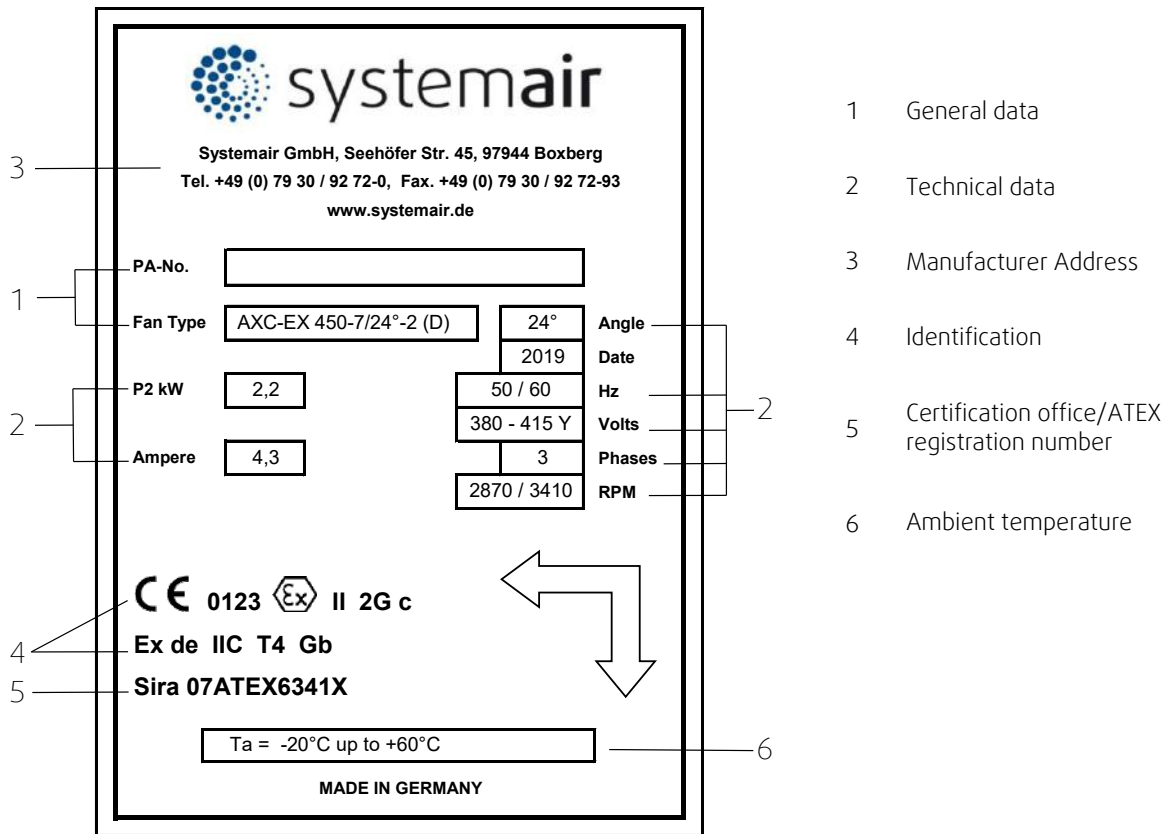

Table 2 Type key

AXC-EX	560	-9	/24°	-2	(D)	Motor type (D): Pressure proof encapsulation (E): Increased safety
AXCBF-EX						
						Blade angle
						Number of blades
						Nominal diameter of the fan
AXC-EX						Axial fan – explosion-proof
AXCBF-EX						Axial fan bifurcated – explosion-proof

6.3 Description AW-EX

Material of the housing:	Galvanized, powder coated steel
Material of the impeller:	Galvanized, powder coated steel
Speed control:	Voltage controllable (See accessories in our online catalogue)
Motor protection:	By integrated thermal contacts
Temperature classes:	T1, T2, T3 (AW-EX355, AW-EX420 -> T4)
Classification:	Zone 1, Zone 2
Category:	2G
Ignition protection class:	Ex e
Group:	IIA, IIB

6.3.1 Accessories



Note:

For details of the accessories, please check our online catalog or contact Systemair.

Table 3 Accessories

1	AW-EX	Axial fan with a wall plate – explosion-proof
2	SG-AW	Protection grille
3	VK	Louvre shutter

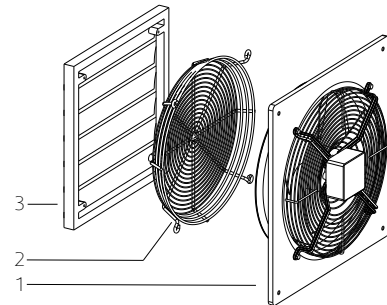

6.3.2 Name plate and type key

- 1 General data
- 2 Technical data
- 3 Manufacturer Address
- 4 Identification
- 5 Certification office/ATEX registration number

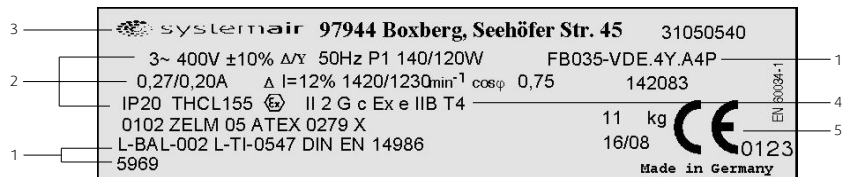
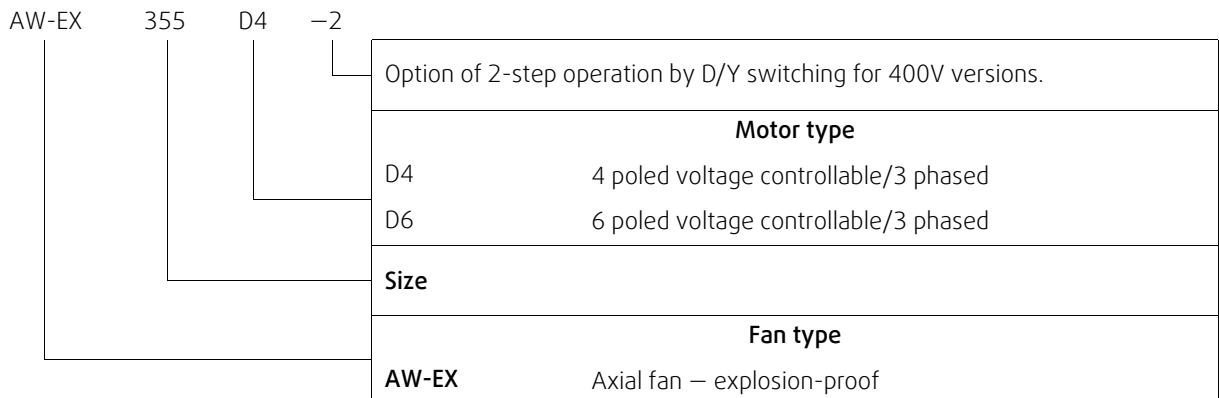

Table 4 Type key



6.4 Description RVK-EX

Material of the housing:	Conductive plastic
Material of the impeller:	Conductive plastic
Speed control:	Voltage controllable (See accessories in our online catalogue)
Motor protection:	By integrated PTC resistor (A motor protection device with EC test type certification has to be used. See accessories in our online catalogue)
Temperature classes:	T1, T2, T3
Classification:	Zone 1, Zone 2
Category:	2G
Ignition protection class:	Ex e, Ex h
Group:	IIA, IIB, Hydrogen

6.4.1 Accessories



Note:

For details of the accessories, please check our online catalog or contact Systemair.

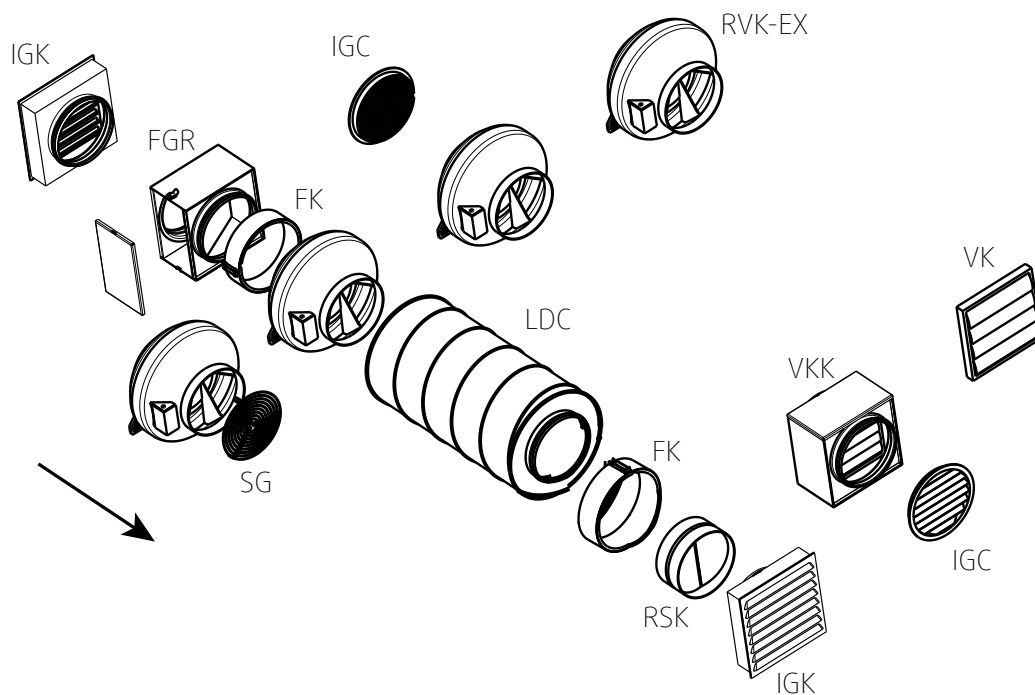

RVK-EX	fan	LDC	Silencer	RSK	Back draft damper
IGC	Round protection grille	VKK	Back draft damper	SG	Protection guard
IGK	Wall grid	VK	Louvre Shutter	FK	Fast clamp
FGR	Filter cassette				

6.4.2 Name plate and type key

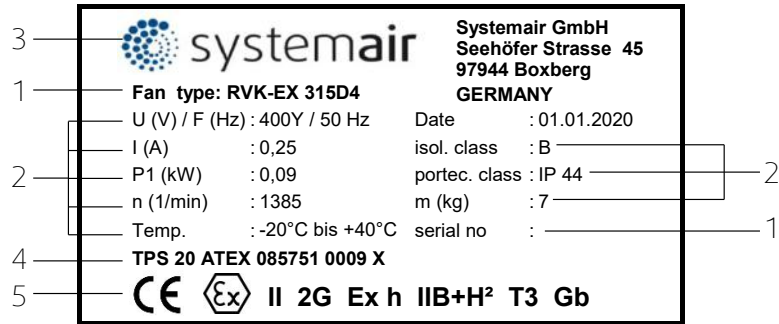

- 1 General data
- 2 Technical data
- 3 Manufacturer Address
- 4 Certification office/ATEX registration number
- 5 Identification

Table 5 Type key

RVK-EX	315	D4		
			Motor type	
			D4	4 poled voltage controllable/3 phased
			Size	
			Fan type	
			RVK-EX	Circular duct fan – explosion-proof

6.5 Description DV-EX

Material of the housing:	Aluminium and Galvanized steel
Speed control:	Voltage controllable (See accessories in our online catalogue)
Motor protection:	By integrated PTC resistor (A motor protection device with EC test type certification has to be used. See accessories in our online catalogue)
Temperature classes:	T1, T2, T3
Classification:	Zone 1, Zone 2
Category	2G
Ignition protection class:	Ex e, Ex h
Group:	IIA, IIB, Hydrogen

6.5.1 Accessories



Note:

For details of the accessories, please check our online catalog or contact Systemair.

Table 6 Accessories

1	DV-EX	Roof fan - explosion-proof
2	VKS-EX	Back draft damper
3	SSD (i)	Socket silencer
4	ASK	Inflow box SSD
5	ASS-EX	Flexible connection
6	ASF	Inlet flange
7	TDA	Adapter framework
8	VKS-EX	Back draft damper
9	FDS (i)	Flat roof socket

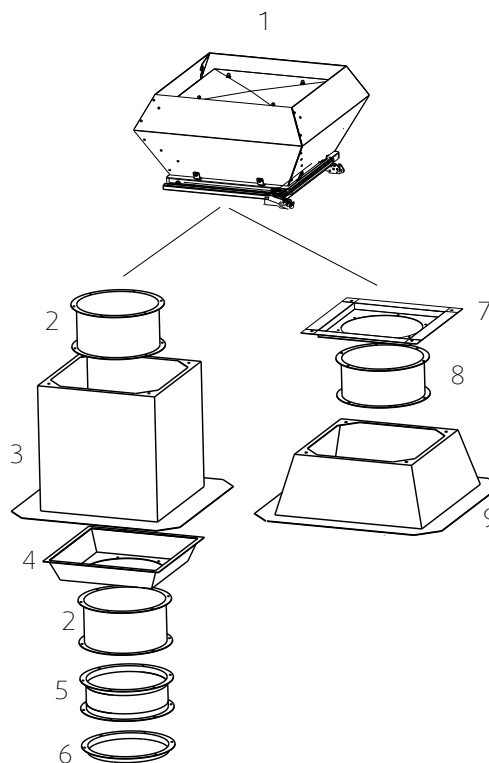

Note:

i. If the degree of inclination is higher than 5°, a SSS (Slanting socket silencer) or a SDS (Slanting roof socket) has to be used.

6.5.2 Name plate and type key

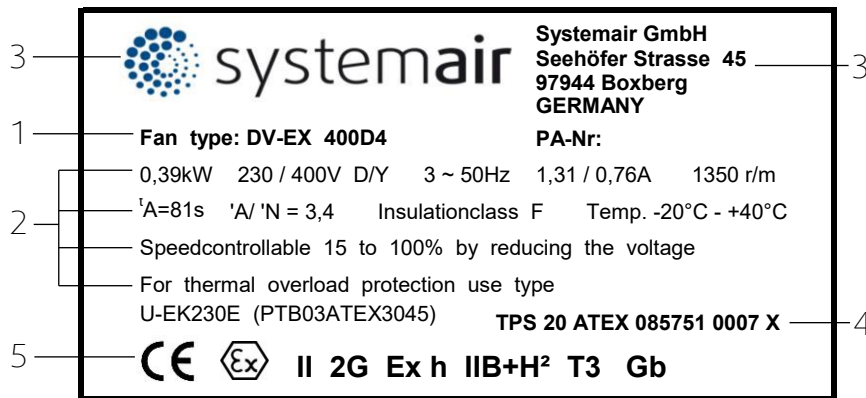

- 1 General data
- 2 Technical data
- 3 Manufacturer Address
- 4 Certification office/ATEX registration number
- 5 Identification

Table 7 Type key

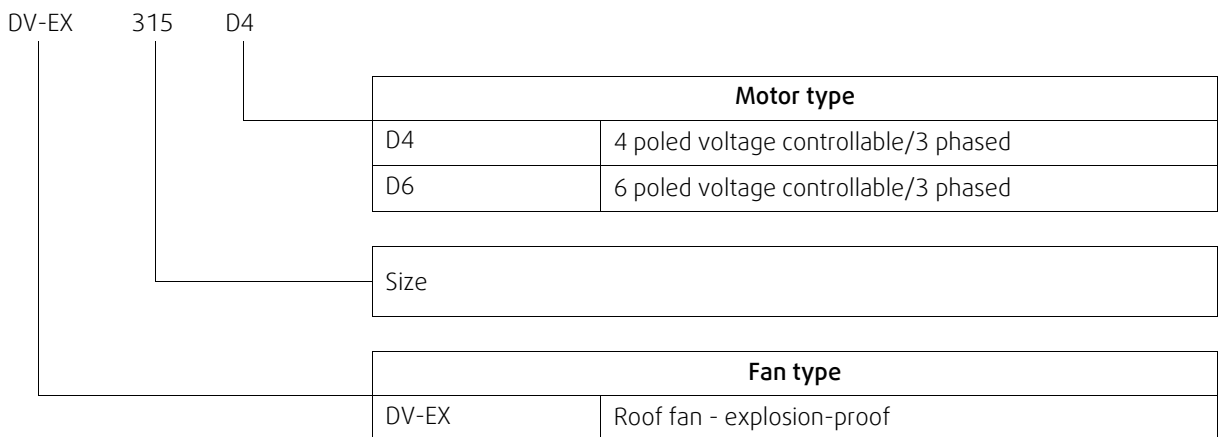

6.6 Description MUB-EX

Material of the housing:	Aluminium and Galvanized steel
Material of the impeller:	Galvanized steel
Speed control:	Voltage controllable (See accessories in our online catalogue)
Motor protection:	By integrated PTC resistor (A motor protection device with EC test type certification has to be used. See accessories in our online catalogue)
Temperature classes:	T1, T2, T3
Classification:	Zone 1, Zone 2
Category	2G
Ignition protection class:	Ex e, Ex h
Group:	IIA, IIB, Hydrogen

6.6.1 Accessories



Note:

For details of the accessories, please check our online catalog or contact Systemair.

Table 8 Accessories

1	FGV	Flexible connection
2	WSG	Weather protection grille
3	WSG	Weather protection guard
4	WSD	Weather protection roof
5	MUB	MUB-EX

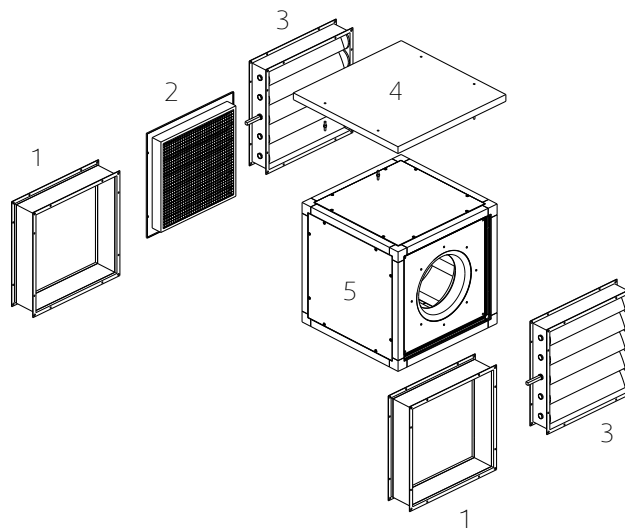

6.6.2 Name plate and type key

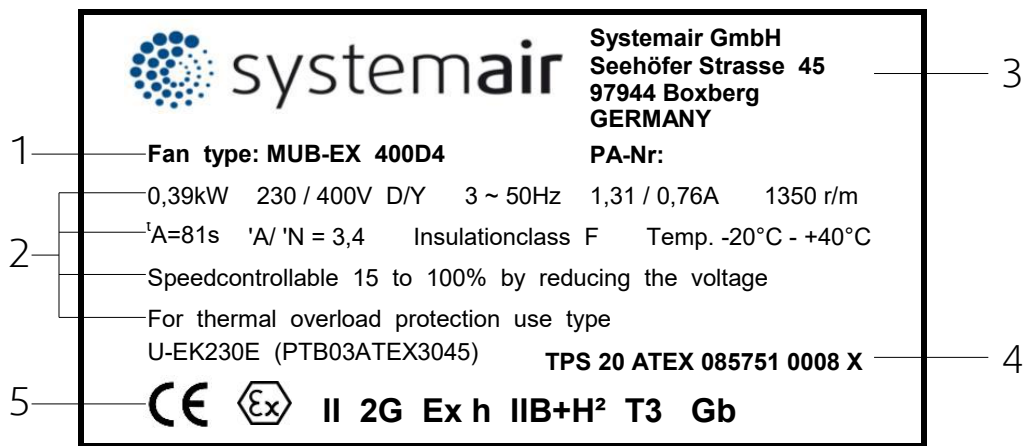

- 1 General data
- 2 Technical data
- 3 Manufacturer Address
- 4 Identification
- 5 Certification office/ATEX registration number

Table 9 Type key

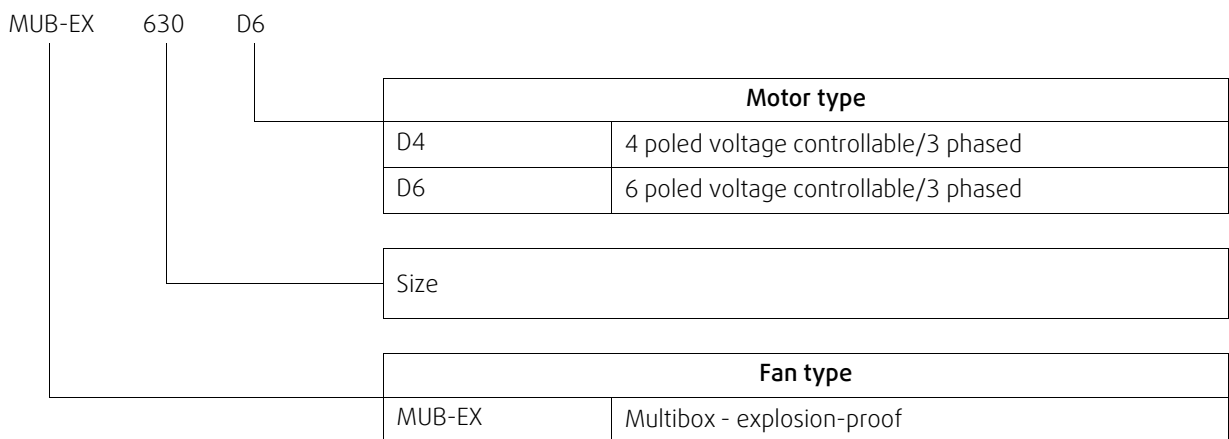

6.7 Technical data

Max. ambient temperature [°C] see data sheet, available in our online catalogue.

Max. temperature of transported air [°C] see data sheet, available in our online catalogue.

Sound pressure [dB] see data sheet, available in our online catalogue.

Voltage, current, frequency, enclosure class, weight see name plate of the fan

The motor data can be found on the name plate of the motor, or in the technical documents of the motor manufacturer.

The data on the name plate of the fan apply to "standard air" according to ISO 5801.

7 Marking

Table 10 Marking

Designation		Marking	
Device group II	Classification		All areas with explosion-capable atmosphere apart from mining, underground and above ground in cases of mien damp.
Device category/ classification	„2G“	2	Category 2 / Zone 1 / high safety / Devices of this category are intended for use in areas in which occasional occurrence of an explosion-capable atmosphere of gases, vapours, mists is to be expected. Increased safety, Ex e.
	„3G“	3	Category 3 / Zone 2 / normal safety / Devices of this category are intended for use in areas in which occurrence of an explosion-capable atmosphere of gases, vapours, mists is not to be expected, but if it does occur then in all probability only rarely and for a short period of time.
		G	Gases / Vapours / Mists
Ignition protection class mechanical	“h”	Constructive safety	DIN EN ISO 80079-37:2016
Ignition protection class electrical	„d“	Pressure-proof encapsulation d	Motor: Pressure-proof encapsulation
	„e“	Increased safety, Ex e	Terminal box: Occurrence of sparks, light arc or inadmissible temperatures which could act as sources of ignition is prevented by additional measures and an increased degree of safety.
Group	II	IIA	Propane
		IIB	Ethylene
		IIC	Hydrogen
Temperature class	T1	450 °C	I: Methane
			IIA: Acetone, ammoniac, methane, methanol, propane, toluene
			IIB: Town gas
	T2	300 °C	IIC: Hydrogen
			IIA: Ethyl alcohol, n-butane
			IIB: Ethylene
T3	200 °C	IIC: Acetylene	
		IIA: Otto fuels, diesel fuels, heating oils	
T4	135 °C	IIB: Hydrogen sulphide	
T5	100 °C	IIA: Acetaldehyde, ethyl ether	
T6	85 °C	There is no gas in this class	
EPL Equipment Protection Level	Gb		Carbon disulphide
			Devices of this category are intended for use in areas in which occasional occurrence of an explosion-capable atmosphere of gases, vapours, mists is to be expected.



8 Installation

Safety information

Warning: Danger from falling fan or fan parts.

- ◆ Check the surface before installation for load bearing capacity.
- ◆ Consider all static and dynamic loads when selecting hoisting equipment and fastening components.

General safety information

- ◆ Installation may only be carried out by adequately qualified persons, details see Table 1 *Qualifications*, page 3.
- ◆ Abide by the system-related conditions and requirements of the system manufacturer or plant constructor.
- ◆ Do not dismantle or circumvent safety elements, or put them out of function.
- ◆ Move the rotor of the fan by hand before you install it in order to check that it moves freely.
- ◆ Provide contact and intake protection and ensure safety distances according to DIN EN ISO13857 and DIN 24167-1.
- ◆ Prevent the possibility of foreign bodies being drawn in.
- ◆ To reduce transmission of vibration to the duct system, we recommend flexible connections from our accessory range, see chapter Accessories.
- ◆ The safety of the fans has to be ensured by protective devices according to DIN EN 294 (DIN EN ISO 12100-1) and DIN 24167-1, the explosion protection measures necessary according to standard DIN EN 13980.

Preconditions

- ◆ Ensure that the fan and all its components are undamaged.
- ◆ Ensure that there is enough space to install the fan.
- ◆ Protect against dust and moisture when installing.
- ◆ Ensure that the information on the name plates (fan and motor) matches up with the operating conditions.
- ◆ Fit the fans in such a way that there is sufficient access for troubleshooting, maintenance and repair.



Danger

Risk of ignition of a potentially explosive atmosphere!

- ◆ Seal the system carefully.
- ◆ Install accessory parts correctly.

Aluminothermic Reaction

At high air speeds, in combination with aluminium, rust particles may lead to an aluminothermic reaction which, in the worst case, can trigger the ignition of an explosive atmosphere. Upstream or downstream components, or those which lie directly in the air flow, must not have any unprotected aluminium or steel surfaces. To prevent an aluminothermic reaction, surface protection is required which at least fulfils the cross-cut test classification 2 / DIN EN ISO 2409. Steel with an electro-galvanised or hot-dip galvanised surface is not critical. However, care must be taken that appropriate protection is also applied to the cut edges.

Important

Damage to the bearings or other parts of the fan can occur.

- ◆ Do not place a duct bend directly before or after the fan!
- ◆ Ensure a smooth and constant air flow to the device.

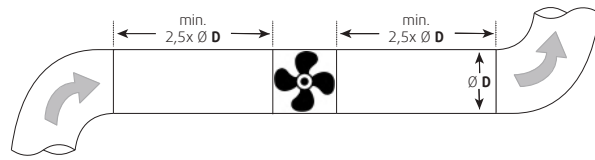

- Round duct system: **D** = Nominal diameter
- Rectangular duct system: **D** = Hydraulic diameter

Air gap

For all work on the fan care should be taken that the gap between the fan impeller and the fixed housing components is regular. The minimum distances must be at least 1 % of the greatest contact diameter, but no less than 2 mm. For double inlet fans the gap must be checked on both inlet sides.

Ensure that the air gap between the housing and the impeller is complied with.

You can find precise information on the minimum air gap of the fans in this chapter.

- ◆ Check if the air gap complies with these data.
- ◆ Do not install the fan if the gap is not complied with the mentioned data.

Below sketch illustrates the different kinds of **air gaps**.

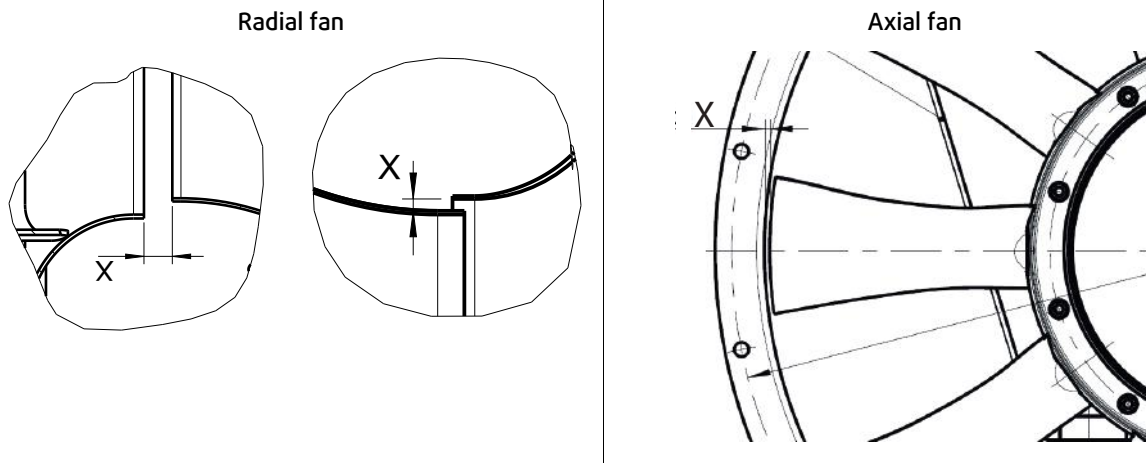

8.1 Installation AW-EX, AXC-EX, AXCBF-EX

Air gap

Table 11 Air gap AW-EX

Nominal diameter	Min. air gap [mm]	Nominal diameter	Min. air gap [mm]
355	3.5	550	5.5
420	4.2	650	6.45

Table 12 Air gap AXC-EX, AXCBF-EX

Nominal diameter	Min. air gap [mm]	Nominal diameter	Min. air gap [mm]
250	2.5	800	5.0
315	2.5	900	7.0
355, 400	3.0	1000	7.0
450, 500	3.5	1120	8.0
560	3.5	1250	8.0
630	4.5	1400	10.0
710	5.0	1600	10.0

Installation positions

AXC-EX, AXCBF-EX

The installation is possible in the mounting positions, see adjacent picture.

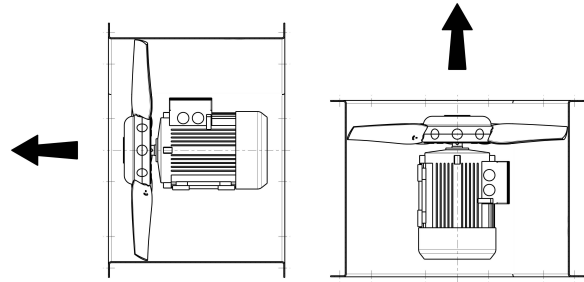

AW-EX

Important

Damage to the fan if condensation water can not drain.
 If installed in a vertical motor shaft position, condensation cannot escape.

- ◆ Install the fan in a horizontal shaft position.

8.2 Installation RVK-EX

Air gap

Table 13 Air gap RVK-EX

Nominal diameter	Min. air gap [mm]
315	2

Installation positions

The installation is possible in any mounting position.

Installation with mounting bracket

Note:
 The mounting bracket is included with the delivery.

- ◆ Mount the mounting bracket on the fan, see adjacent image.

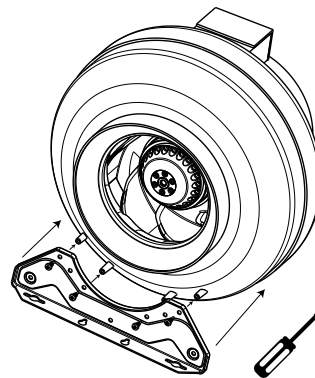

8.3 Installation DV-EX

Air gap

Table 14 Air gap DV-EX

Nominal diameter	Min. air gap [mm]	Max. air gap [mm]
all sizes	4	8



Warning

Danger of injury by tilting the fan during installation.

- ◆ The tilting device must be secured in the opened state by screws in the designated hole against unintentional folding.

8.4 Installation MUB-EX

Air gap

Table 15 Air gap MUB-EX

Nominal diameter	Min. air gap [mm]
025 315	2.5
042 355	5
042 400	4
042 450	4
062 560	3.5
062 630	2.5

Important

Overheating motor

- ◆ The installation distance must correspond to the adjacent image. If the motor protrudes out of the housing, the distance between other motors/multiboxes or a wall has to be $1 \times A$.
- ◆ As well as adhering to the maximum ambient temperature (see fan data sheet), care must be taken that the ventilation for the motors is sufficient. Trapped heat must be avoided at all costs.

Distance to a wall

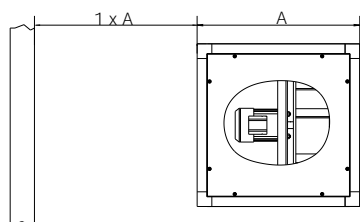

Distance to a MUB

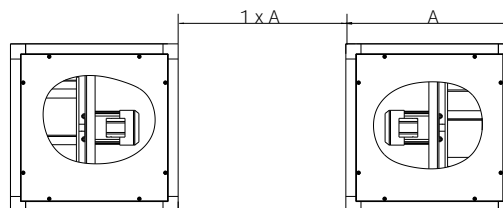

Installation positions

The installation is possible in any mounting position.

Changing the discharge direction

As a default, the Multiboxes have been designed for an inline airflow direction. The airflow can be changed from inline to 90° by replacing the side panels.

Legend

1. MUB-EX with inline airflow direction (factory assembly)
2. MUB-EX with 90° airflow direction
3. Change of airflow direction

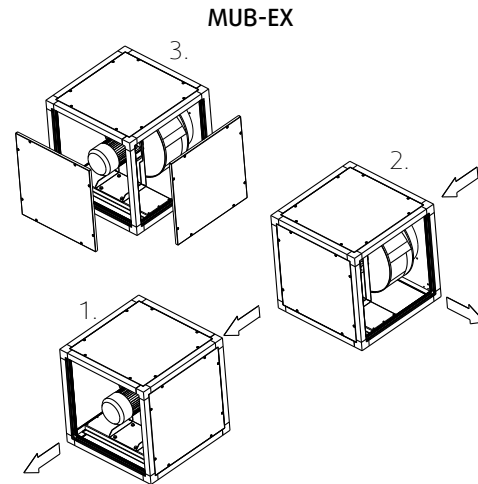

8.4.1 Lightning protection device

- ◆ If the risk assessment shows that there is the risk of an atmospheric discharge, lightning protection measures must be taken. For reasons of operational safety, provide for a suitable lightning protection system according to country specific directives (e.g. DIN VDE 0185).

9 Electrical connection

Safety information



Danger

Risk of ignition of a potentially explosive gas/air atmosphere!

If the fan is connected to electricity via an additional connection box (not included in the scope of delivery) in explosion capable area, the following points must be observed:

- ◆ A connection box (with its own certification and explosion-protection identification) which has been selected as suitable for this area must be used.
- ◆ Whether the technical characteristics of components match the requirements of the explosion capable area must be checked by the customer.

Protection against explosions regarding use of accessories:

- ◆ Electronic accessories without explosion-protection (e.g. RTRD control device and UEK motor protection) must be installed outside the explosion capable area.
- ◆ Speed control by frequency converter is only admissible for devices with the „Pressure-proof encapsulation Ex d“ ignition protection class.

Protection against explosions in general:

- ◆ Earth at the planned earthing point.
- ◆ In hazardous areas connect conductive components to a potential equalisation system.

Warning: Danger from electrical voltage!

- ◆ Observe the 5 rules of electrical safety, see 3.3 5 rules of electrical safety, page 3.
- ◆ Prevent the ingress of water into the connection box.
- ◆ Electrical connection may only be carried out by adequately qualified persons, details see Table 1 Qualifications, page 3.

Preconditions

- ◆ Potentially, the fans may become charged with static electricity. If this represents a risk, please contact Systemair.
- ◆ If fans with motors of ignition protection class „d“ are controlled by frequency converter, a thermal protection (PTC) in the motor is necessary.

Connection

- ◆ Check if the data on the nameplate matches the connection data.
- ◆ Complete the electrical connection according to the circuit diagram.
- ◆ Use all of the locking screws.
- ◆ Insert the screws by hand to avoid damaging the thread.
- ◆ Tighten all glands well in order to guarantee protection class IP.
- ◆ Screw the lid of the terminal box/inspection switch evenly tight.
- ◆ Connect the cable end in a dry environment.
- ◆ Install a circuit breaker in the permanent electrical installation, with a contact opening of at least 3 mm at each pole.
- ◆ Potentially, the fans may become charged with static electricity. If this represents a risk, please contact Systemair.

Protective grounding wire

The protective grounding must have a cross-section equal to or greater than that of the phase conductor.

Residual current circuit breaker

All-current-sensitive residual current circuit breakers are required for use in alternating-current systems with 50/60 Hz, in combination with electronic devices such as EC motors, frequency converters or uninterruptible power supplies (UPS).

9.1 Protecting the motor

Important

Damage to motor due to overcurrent, overload or short circuit.

- ◆ Lead-out temperature monitors must be integrated in the control circuit in such a way that, if a fault occurs, the motor cannot switch on again automatically after it has cooled down.
- ◆ Motor lines and temperature monitor lines should be laid separately on principle.
- ◆ Without thermal protection: Use a motor protection switch!

9.2 Variable-speed fans



Warning

Resonant frequencies may result increased vibration in certain speed ranges. These vibrations may destroy components.

- ◆ Only operate the fan outside these speed ranges.
- ◆ Pass through these speed ranges so quickly that any vibration cannot exceed the admissible resonant frequency values.
- ◆ Observe the operating instructions of the frequency converter.



Caution

Damage as a result of incorrect commissioning of the frequency converter.

- ◆ Install the fan and frequency converter as near as possible to one another.
- ◆ Use shielded cables.
- ◆ All components (fan, frequency converter and motor) must be grounded.
- ◆ Avoid running the fan via the frequency converter below 10 Hz.
- ◆ Heating of the motor due to use of a variable frequency drive must be checked in the application by the customer.
- ◆ Never exceed the maximum impeller rotation speed indicated on the name plate of the fan.
- ◆ An all-pole sine filter is mandatory if the fan is operated with a frequency converter.

10 Commissioning

The system operator is responsible for the correct operation of the fan and/or the system!

Warranty claims can only be made if commissioning work is carried out correctly and written evidence thereof is provided.

It is recommended to fill out the commissioning report 16 *Commissioning Report*, page 27.



Danger

Risk of ignition of a potentially explosive gas/air atmosphere!

- ◆ When commissioning the EX fan, the fundamental information from DGUV 113-001 (explosion protection rules (EX-RL)) and TRGS 727 (avoidance of risk of ignition as a result of electrostatic charges) must be known.
- ◆ Observe and respect local conditions, regulations and laws.

10.1 Safety information

- ◆ Commissioning may only be carried out by adequately qualified persons, details see Table 1 *Qualifications*, page 3.
- ◆ Pay attention to the safety data sheet of the chemical substances transported with the fan.



Warning

- ◆ Comply with fundamental information in the commissioning of the EX fan:
 - DGUV 113-001 (explosion protection rules (EX-RL))
 - TRGS 727 (avoidance of risk of ignition as a result of electrostatic charges).
 - Observe and respect local conditions, regulations and laws.

10.2 Preconditions

- ◆ Installation and electrical connection have been correctly performed.
- ◆ Residual material from installation and foreign objects have been removed from the fan and ducts.
- ◆ Inlet and outlet are free.
- ◆ Safety devices have been fitted.
- ◆ Ground cable is connected.
- ◆ Cable glands are tight.
- ◆ Data on the name plate corresponds with the connection data.
- ◆ For EX fans, check whether the minimum air gap between the rotor and the housing matches the value stated in 8 *Installation*, page 16

10.3 Tests

- ◆ Check if the air gap of the fans are according to the values in the chapter 6 *Description*, page 5.
 - ◆ Before switching the fan on, check for externally visible damage and ensure that the protective equipment functions properly.
1. Switch the fan on.
 2. Do the tests requested in the commissioning report (16 *Commissioning Report*, page 27)
 - Speed controllable fans: "Measured data at commissioning" at maximum speed
 3. Switch the fan off.

11 Operation

11.1 Safety information



Danger

Risk of ignition of a potentially explosive gas/air atmosphere!

When commissioning the EX fan, the fundamental information from DGUV 113-001 (explosion protection rules (EX-RL)) and TRGS 727 (avoidance of risk of ignition as a result of electrostatic charges) must be known.

- ◆ Do not open or tip the fan if an explosive atmosphere exists.

Warning: Hazard from electrical voltage or moving components.

- ◆ The fan may only be operated by adequately qualified persons, details see Table 1 *Qualifications*, page 3.

Important

Damage to the fan because of condensation water.

Ensure regular switch-on time of 2 hours per week

- ◆ Only use the fan in accordance with the operating instructions and the operating instructions for the motor.
- ◆ The EX fans have been admitted for S1 continuous operation.

12 Troubleshooting/maintenance/repair

Safety information

- ◆ Observe 3 *Important safety information*, page 2



Danger

Loss of explosion protection

- The manufacturer must always be consulted before any maintenance or repair work is carried out! Repairs should preferably always be carried out by the manufacturer! Exceptions can be made for non-relevant components such as terminal boxes, screwed cable connections, etc. These can also be dealt with on-site by the operator's qualified staff (authorised personnel). Non-compliance will result in the ATEX certification being revoked!
- For ATEX-certified products, the repair or replacement of fan components is expressly only permitted after consultation with the manufacturer and only if the manufacturer's original parts are used!
- After repair, the fan/system must be subjected to an inspection in accordance with local conditions, regulations and laws (in Germany: §14 Abs 6 der BetrSichV Industrial Safety Regulation). This does not apply to repairs carried out by the manufacturer.

12.1 Troubleshooting

Problem	Possible causes	Remedy
Fan does not run smoothly	Impeller imbalance	Rebalancing by a specialist company if possible, otherwise contact Systemair.
	Soiling on the impeller	Clean carefully, rebalance
	Material decomposition on the impeller due to aggressive material conveyed.	Contact Systemair
	Impeller rotates in wrong direction.	Change direction of rotation (swap two phases in case of a 3- phase motor). Contact Systemair
	Deformation of impeller due to excessive temperature.	Ensure that the temperature does not exceed the certified value/Install new impeller.
	Vibrations, oscillations	Check the installation of the fan/check the duct system, see 8 <i>Installation</i> , page 16.
	Fan operation in resonant frequency range	Consider chapter 9.2 <i>Variable-speed fans</i> , page 21
Air output of fan too low	Impeller rotates in wrong direction.	Change direction of rotation (swap two phases in case of a 3- phase motor). Contact Systemair
	Wrong wiring configuration (e.g. Y instead of Delta).	Check and possibly correct the wiring configuration.
	Pressure losses too high.	Optimize the line routing.
	Flow regulators not or only partly open.	Check opening position on site.
Thermal contacts/ resistors have triggered	Intake or pressure ducts are blocked.	Remove the blockage.
	Impeller rotates in wrong direction.	Change direction of rotation (swap two phases in case of a 3- phase motor).
	Missing phase	In case of a 3 phase standard motor (not EC), check if all 3 phase are present.
	Motor overheated	Check the cooling impeller (if used). Contact Systemair
Fan does not reach nominal speed	Motor blocked	Contact Systemair
	Defective motor winding	Check the winding by resistance measurement (if possible). Contact Systemair
Motor does not rotate	Control units (if used) such as frequency converter or transformer are set incorrectly.	Correct the settings of the control units.
	Faulty supply voltage	Check the supply voltage, re-establish the voltage supply.
	Mechanical blockage	Remove the blockage.
	Frozen condensate blocking the impeller	Thaw and drain the condensate
	Faulty connection	Disconnect from the power supply, correct the connection, see circuit diagram.
Electronics/ motor overheated	Temperature monitor has responded.	Allow the motor to cool down, find and resolve the cause of the fault.
	Insufficient cooling	Improve cooling.
	Overloaded motor	Check if the correct fan is used for your application.
	Ambient temperature too high	Check if the correct fan is used for your application. Improve cooling.

**Note:**

For all other damage/defects, please contact Systemair. Defective safety-relevant fans (for Ex and smoke extraction applications) must be replaced completely.

12.2 Maintenance

Warranty claims can only be made if maintenance work is carried out correctly and written evidence thereof is provided.

We recommend regular maintenance intervals to ensure continuous fan operation. These maintenance intervals are specified in the "Activities" table below. In addition, the operator must carry out follow-up activities such as cleaning, replacing defective components or other corrective measures. For traceability reasons, a maintenance plan must be created which documents the work carried out. This must be created by the operator. If the operating conditions are "extreme", the maintenance intervals must be reduced so that maintenance is carried out more frequently. Examples of extreme operating conditions:

- Durable ambient temperature $> 35\text{ °C}$ or $< 5\text{ °C}$, or temperature fluctuations $> 20\text{ K}$
- Use in an explosion capable area

Table 16 Activities

Activity	Normal operating conditions		Extreme operating conditions	
	Every six months	Annually	Quarterly	Every six months
Check the fan and its components for visible damage, corrosion and contamination.		X		X
Check the impeller for damage and imbalance.		X		X
Clean the fan/ventilation system (see 13 <i>Cleaning</i> , page 25).	X		X	
Check the screwed connections for damages/defects and check that they are firmly seated.		X	See normal operating conditions	
Check the fan intake is free from contamination.		X		X
Check that the fan and its components are being used correctly.	X		See normal operating conditions	
Check the current consumption and compare this with the rated data.		X		X
Check the vibration dampers (if used) are working correctly and check for visible damage and corrosion.		X	See normal operating conditions	
Check the electrical and mechanical protective equipment is working correctly.		X	See normal operating conditions	
Check the fan's rating plate is legible.		X		X
Check the connection clamps and screwed cable connections for damage/defects, and check that they are firmly seated.		X	See normal operating conditions	
Check the flexible connectors for damage.	X		See normal operating conditions	

13 Cleaning

13.1 Safety information

- ◆ Cleaning may only be carried out by adequately qualified persons, details see Table 1 *Qualifications*, page 3.
- ◆ Observe the 5 rules of electrical safety, see 3.3 *5 rules of electrical safety*, page 3.
- ◆ The impeller must be at a standstill.
- ◆ Pay attention to the safety data sheet of the chemical substances transported with the fan.



Warning

Risk of ignition as a result of electrostatic charges.

Because of the MUB EX plastic parts in the housing, a damp cloth has to be used for cleaning to avoid the risk of ignition as a result of electrostatic charges.

13.2 Procedure

Important

Keeping the fan clean extends its service life.

- ◆ Drain condensation off
- ◆ Only use compressed air if the fan is used for conveying air in the presence of gases/vapours without hovering particles.
- ◆ If the fan is used in an environment with vapours of specific chemical substances, get information from the chemical safety data sheet with a view to the recommended cleaning products.
- ◆ Install a filter monitor.
- ◆ Do not use steel brushes or sharp-edged objects.
- ◆ Do not use a high-pressure cleaner (steam jet cleaner) under any circumstances.
- ◆ Do not bend the fan blades when cleaning.
- ◆ When cleaning the impeller, pay attention to balance weights that have been positioned
- ◆ Keep the airways of the fan clear and clean them if necessary with a brush.

14 Deinstallation/dismantling

- ◆ Pay attention to the safety data sheet of the chemical substances transported with the fan.
- Deinstall and dismantle the fan in reverse order of installation and electrical connection.

15 Disposal

- ◆ Ensure material is recycled. Observe national regulations.
- ◆ The device and the transport packaging are predominantly made from recyclable raw materials.
- ◆ Disassemble the fan into its components.
- ◆ Separate the parts according to:
 - reusable material
 - material groups to be disposed of (metal, plastics, electrical parts, etc.)

16 Commissioning Report

Warranty claims can only be made if commissioning work is carried out correctly and written evidence thereof is provided.

Fan

Description:

Article no.:

Manufacturing order no.:

Installer

Company:

Contact person:

Company address:

Tel. no.:

Email:

Operator (Place of installation)

Company:

Contact person:

Company address:

Tel. no.:

Email:

Type of connection

Yes No

Directly to mains

0-10 V signal (EC motor)

via contactor control

Transformer

Frequency converter

Sinus filter

Shielded cables

Motor protection

Yes No

Motor protection switch or motor protection relay

PTC resistor

Resistance value [Ω]:

Thermal contact

Electrical motor protection

Others:

Functional check

Yes No

Impeller easily rotatable (by hand)

Rotation direction acc. to directional arrow

Smooth running without unusual noise/
vibrations

Nominal data - Fan (name plate on fan housing)

Voltage [V]:

Current [A]:

Frequency [Hz]:

Power [kW]:

Fan impeller speed [rpm]:

Measured data at commissioning

Voltage [V]:

Temp. of transported air [$^{\circ}$ C]:

Current L1 [A]*:	Fan impeller speed [rpm]:
Current L2 [A]:	Air volume [m3/s]:
Current L3 [A]:	Differential pressure [Pa]*:
*For single-phase fans, fill in line "Current L1 [A]"	*Δ- Pressure between suction-side and discharge of the fan

If an air flow measurement is not possible, this value can be calculated using the following formula:

$$\text{Duct cross-section [m}^2\text{]} \times \text{Flow speed [m/s]} = \text{Air volume [m}^3\text{/s]:}$$

Grille measurement acc. to VDI 2044

	Yes	No
Commissioning of the fan successful?	<input type="checkbox"/>	<input type="checkbox"/>

Date, installer's signature

Date, operator's signature



Systemair GmbH
Seehöfer Str. 45
97944 Boxberg
Germany

Tel.: +49 (0)7930/9272-0
Fax: +49 (0)7930/9273-92

info@systemair.de
www.systemair.de